

CLASS 2 UNIVERSAL MOUNT TRANSFORMERS – 40 & 50VA

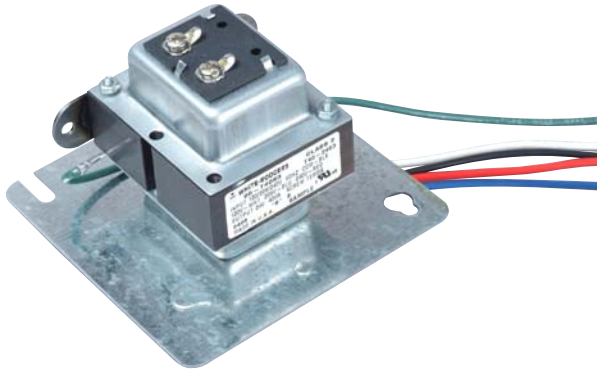

GENERAL INFORMATION

Safety Agency Certification: **UL** U.S. U.L. File No. E33334
 Recognized under Category XOKV2/XOKV8
 NEC Classification: Class 2, Inherently Limited
 U.L. Insulation Class: Class B (130°C Max)
 Output Voltage: 24VAC

APPLICATIONS:

- Commercial Dryers
- Deep Fryers
- Greenhouse Controls
- HVAC – Heating, Ventilation, Air Conditioning Systems
- Security Systems
- Video Games
- Automatic Doors
- Solar Heating Controls

AVAILABLE INPUT VOLTAGES:

- 120V, 208/240V and 120/208/240V

TRANSFORMER TERMINATIONS:

- 11" Color Coded Leads on Primary
- Screw Terminals on Secondary

FEATURES:

- Convenient Mounting Plate
- Metal Coil Covers
- Universal Mounting Includes 4 x 4 Mounting Plate

OUTLINE DRAWING

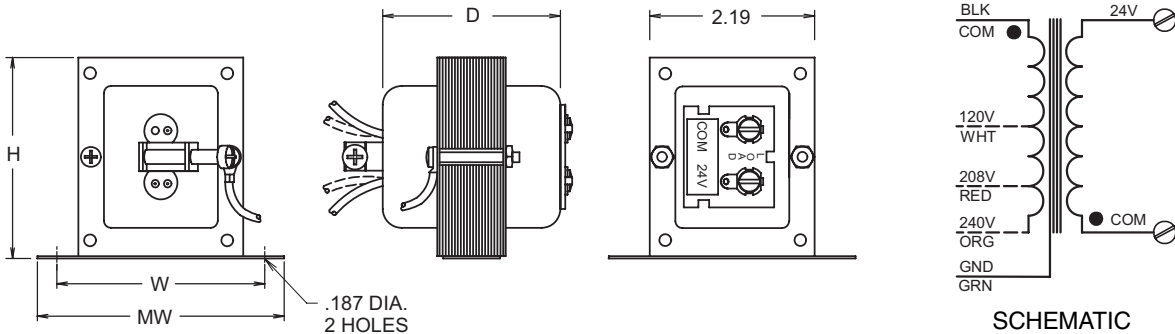

W-R PART NUMBER	STANCOR PART NUMBER	INPUT VOLTAGE	FREQ Hz	OUTPUT VOLTAGE	OUTPUT CURRENT	VA	MOUNTING	PRI TERM.	SEC TERM.	DIMENSIONS-INCHES				Wt. (Lbs)
										H	W	D	MW	
90-T40S1	T40-24S1	120	60	24	1.67	40	UNIVERSAL	LEADS	SCREWS	2.75	3.25	2.44	2.81	1.85
90-T40S2	T40-24S2	208/240	50/60	24	1.67	40	UNIVERSAL	LEADS	SCREWS	2.75	3.25	2.44	2.81	1.85
90-T40S3	T40-24S3	120/208/240	60	24	1.67	40	UNIVERSAL	LEADS	SCREWS	2.75	3.25	2.44	2.81	1.85
90-T50S3	T50-24S3	120/208/240	60	24	2.08	50	UNIVERSAL	LEADS	SCREWS	2.75	3.25	2.81	2.81	2.10