

CLASS 2 FOOT MOUNT TRANSFORMERS – 100VA

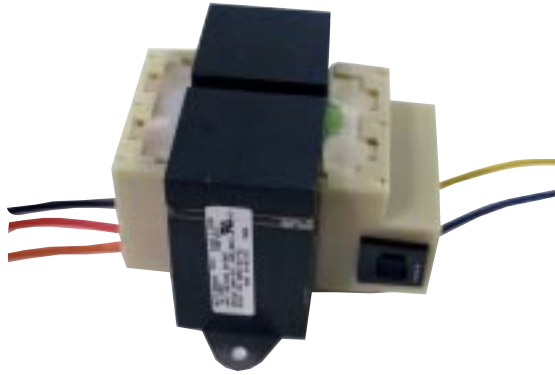

APPLICATIONS:

- Commercial Dryers
- Deep Fryers
- Greenhouse Controls
- HVAC – Heating, Ventilation, Air Conditioning Systems
- Security Systems
- Video Games
- Automatic Doors
- Solar Heating Controls

AVAILABLE INPUT VOLTAGES:

- 120V or 208/240V

TRANSFORMER TERMINATIONS:

- 11" Color Coded Leads

FEATURES:

- Convenient Mounting Plate
- Protective Plastic Covers
- Integral Circuit Breaker Protected

GENERAL INFORMATION

Safety Agency Certification:  U.S. U.L. File No. E33334

Recognized under Category XOKV2/XOKV8

NEC Classification: Class 2

U.L. Insulation Class: Class B (130°C Max.)

Output Voltage: 25VAC

OUTLINE DRAWING

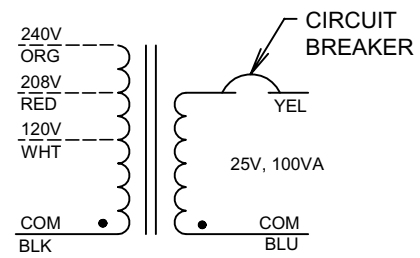
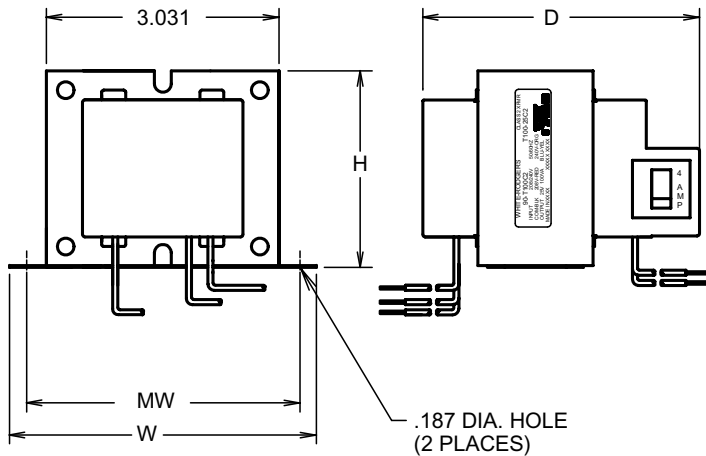

SCHEMATIC

W-R PART NUMBER	STANCOR PART NUMBER	INPUT VOLTAGE	FREQ Hz	OUTPUT VOLTAGE	OUTPUT CURRENT	VA	MOUNTING	PRI TERM.	SEC TERM.	DIMENSIONS-INCHES				Wt. (Lbs)
										H	W	D	MW	
90-T100C1	T100-25C1	120	60	25	4.00	100	FOOT	LEADS	LEADS	2.62	4.00	3.38	3.56	2.65
90-T100C2	T100-25C2	208/240	50/60	25	4.00	100	FOOT	LEADS	LEADS	2.62	4.00	3.63	3.56	3.00